

## V10 & V20 Single Vane Pump

- Versatile
- Reliable
- High Performance
- Cost efficient



## V10 & V20 Single Vane Pump

### Versatile

High flow, pressure and speed capabilities enable these pumps to meet the needs of modern vehicle hydraulic circuits. Optional flow control and priority valve covers offer even more versatility.

### Flow Control

The flow control cover limits flow to the operating system to the desired maximum. Excess flow is diverted to tank. On double pumps, shaft-end pump delivery is proportional to speed.

The flow control cover also includes a relief valve to limit maximum system pressure.

A typical application of a flow control is in a power steering unit where it provides a constant supply of oil over the engine's mid to high speed range.

### Priority Valve

The priority valve cover maintains nearly a constant flow to a primary circuit and diverts the remaining flow to a secondary circuit. Flow going to the secondary circuit is determined by pump delivery. The primary circuit is protected by an integral relief valve but an external relief valve must be provided for the secondary circuit.

### Reliable

The superior design of these units makes them last longer ... they've proven they'll hold up in rugged applications such as trenchers, backhoes and tractors.

### Hydraulic Balance

Internal inlet and outlet pressure chambers are diametrically opposed.

As a result, pressure-induced radial loads are balanced ... bearings have to carry the external load only.

### Performance

Low vane tip/ring loading allows high pressure operation. High speeds are possible because the inlet flow paths are designed to give uniform oil acceleration - thus better filling - particularly at low inlet pressures.

### Low Cost

FluiDyne Fluid Power's efficient design produces extra horsepower per dollar of pump investment - providing industry with low pump cost per horsepower capacity.

## Single Pump Operating Specifications

Model Series	Delivery USgpm @ 1200 rpm 7 bar (100 psi)	Displ. cm <sup>3</sup> /r (in <sup>3</sup> /r)	Max. r/min	Max. bar (psi)	Typical del.. L/min (USgpm) @ max. speed & pressure	Typical input kW (hp) @ max. speed & pressure	Wt. kg (lb.)
V10 V10(N)F V10P	1	3,3 (.20)	4800	172 (2500)	13,6 (3.6)	5,2 (7)	4,5 - 6,8 (10 - 15)
	2	6,6 (.40)	4500	172 (2500)	27,7 (7.3)	10,1 (13.6)	
	3	9,8 (.60)	4000	172 (2500)	35,6 (9.4)	13,3 (17.8)	
	4	13,1 (.80)	3400	172 (2500)	41,3 (10.9)	15,2 (20.4)	
	5	16,4 (1.00)	3200	172 (2500)	48,5 (12.8)	17 (22.8)	
	6	19,5 (1.19)	3000	152 (2200)	55,3 (14.6)	18,3 (24.5)	
	7	22,8 (1.39)	2800	138 (2000)	60,6 (16)	17,9 (24)	
V20 V20F V20NF V20P	6	19,5 (1.19)	3400	172 (2500)	61,0 (16.1)	21,6 (29)	7,3 - 8,2 (16 - 18)
	7	22,8 (1.39)	3000	172 (2500)	63,3 (16.7)	22 (29.5)	
	8	26,6 (1.62)	2800	172 (2500)	67,1 (17.7)	24,2 (32.5)	
	9	29,7 (1.81)	2800	172 (2500)	75,0 (19.8)	26,5 (35.5)	
	10	31,5 (1.93)	2500	172 (2500)	81,0 (21.4)	27,3 (36.6)	
	11	36,4 (2.22)	2500	172 (2500)	86,8 (22.9)	28 (37.5)	
	12	39,0 (2.38)	2400	152 (2200)	87,2 (23)	26,8 (36)	
13	42,5 (2.59)	2400	152 (2200)	98,1 (25.9)	29,1 (39)		

Note: Applicable equations and start-up procedures at end of document.

Model Codes

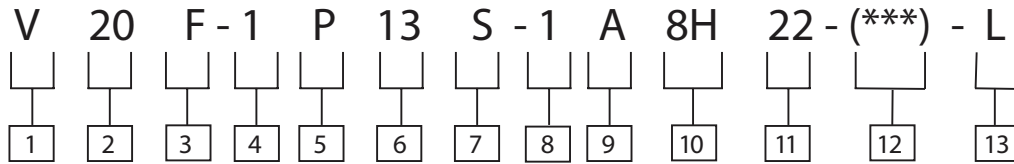

1 Vane pump

2 Series  
10 or 20

3 Integral valve options  
(Omit if not required)

- F – Flow control & relief
- P – Priority valve & relief
- NF – Flow control & relief w/internal drain

4 Mounting

- 1 – 2-bolt flange
- 6 – 2 bolt flange (SAE "B" size)

5 Inlet port connections

- D – 1 5/16"-12 str. thd. (V20 only)
- P – 1" NPT thread (V10 only)
- 1 1/4" NPT thread (V20 only)
- S – 1 5/16"-12 str. thd. (V10 only)
- 1 5/8"-12 str. thd. (V20 only)
- T – 1 3/16"-12 str. thd. (V10 only)

6 SAE rated capacity – USgpm  
(1200 r/min & 100 psi)

- |    |                       |            |
|----|-----------------------|------------|
| 1  | – 4 L/min (1 USgpm)   | V10 series |
| 2  | – 8 L/min (2 USgpm)   |            |
| 3  | – 11 L/min (3 USgpm)  |            |
| 4  | – 15 L/min (4 USgpm)  |            |
| 5  | – 19 L/min (5 USgpm)  |            |
| 6  | – 23 L/min (6 USgpm)  |            |
| 7  | – 27 L/min (7 USgpm)  |            |
| 6  | – 23 L/min (6 USgpm)  | V20 series |
| 7  | – 27 L/min (7 USgpm)  |            |
| 8  | – 30 L/min (8 USgpm)  |            |
| 9  | – 34 L/min (9 USgpm)  |            |
| 10 | – 39 L/min (10 USgpm) |            |
| 11 | – 42 L/min (11 USgpm) |            |
| 12 | – 45 L/min (12 USgpm) |            |
| 13 | – 49 L/min (13 USgpm) |            |

7 Outlet port connections

Code	Flow control cover		Priority valve cover			
	Std. cover	Pressure	Tank	Primary outlet	Secondary outlet	Tank
K	–	–	–	9/16-18 St. thd. (V10P)	3/4-16 St. thd. (V10P)	9/16-18 St. thd. (V10P)
	1/2" NPT thd. (V10 only)	–	–	–	–	–
P	3/4" NPT thd. (V20 only)	3/4-16 St. thd (V10F & V20F)	1/2" NPT thd. (V10F & V20F)	–	–	–
R	1-1/16"-12 St. thd (V10 only)	–	–	–	–	–
	1-3/16"-12 St. thd (V20 only)	–	–	–	–	–
S	3/4"-16 St. thd. (V10 only)	–	–	–	–	–
	1-1/16"-12 St. thd. (V20 only)	3/4-16 St. thd. (V20F)	1-1/16"-12 St. thd. (V20F)	–	–	–
T (NF only option)	–	3/4-16 St. thd. (V10F)	3/4-16 St. thd. (V10F)	3/4-16 St. thd. (V20P)	7/8-14 St. thd. (V20P)	3/4-16 St. thd. (V20P)
	–	3/4-16 St. thd. (V10NF & V20NF)	–	–	–	–

8 Shafts

- 1 – Straight keyed
- 3 – Threaded with woodruff key
- 11 – Splined
- 12 – Splined (V10 only)
- 38 – Splined
- 62 – SAE A Spline (V20 only)

11 Design

Subject to change. Installation dimensions remain the same for designs –20 through –29.

9 Position of outlet or primary outlet port

- (Viewed from cover end of pump)
- A – Opposite inlet port
  - B – 90° CCW from inlet
  - C – In line with inlet
  - D – 90° CW from inlet

12 Special Suffix Feature  
(Omit if not required)

13 Shaft Rotation

- (Viewed from shaft end of pump)
- L – Left hand for counterclockwise.
  - R – Right hand or ( Omit )

10 Integral valves

Flow rate	Relief valve setting	
2 – 8 L/min (2 USgpm)	A – 17 bar (250 psi)	H – 140 bar (2000 psi)
3 – 11 L/min (3 USgpm)	B – 35 bar (500 psi)	J – 155 bar (2250 psi)
4 – 15 L/min (4 USgpm)	C – 52 bar (750 psi)	K – 175 bar (2500 psi)
5 – 19 L/min (5 USgpm)	D – 70 bar (1000 psi)	L – 190 bar (2750 psi)
6 – 23 L/min (6 USgpm)	E – 86 bar (1250 psi)	0 – Custom Setting (Noted by Suffix)
7 – 27 L/min (7 USgpm)	F – 100 bar (1500 psi)	
8 – 30 L/min (8 USgpm)	G – 121 bar (1750 psi)	

## Installation Dimensions

### V10 Series

Dimensions in millimeters (inches).  
Additional shaft options shown on page 7.

Delivery @ 1200 rpm & 100 psi	Dimensions	
	A	B
1 USgpm	115,6 (4.55)	91,9 (3.62)
2 USgpm	115,6 (4.55)	91,9 (3.62)
3 USgpm	115,6 (4.55)	91,9 (3.62)
4 USgpm	121,9 (4.80)	98,3 (3.87)
5 USgpm	121,9 (4.80)	98,3 (3.87)
6 USgpm	127,0 (5.00)	103,4 (4.07)
7 USgpm	127,0 (5.00)	103,4 (4.07)

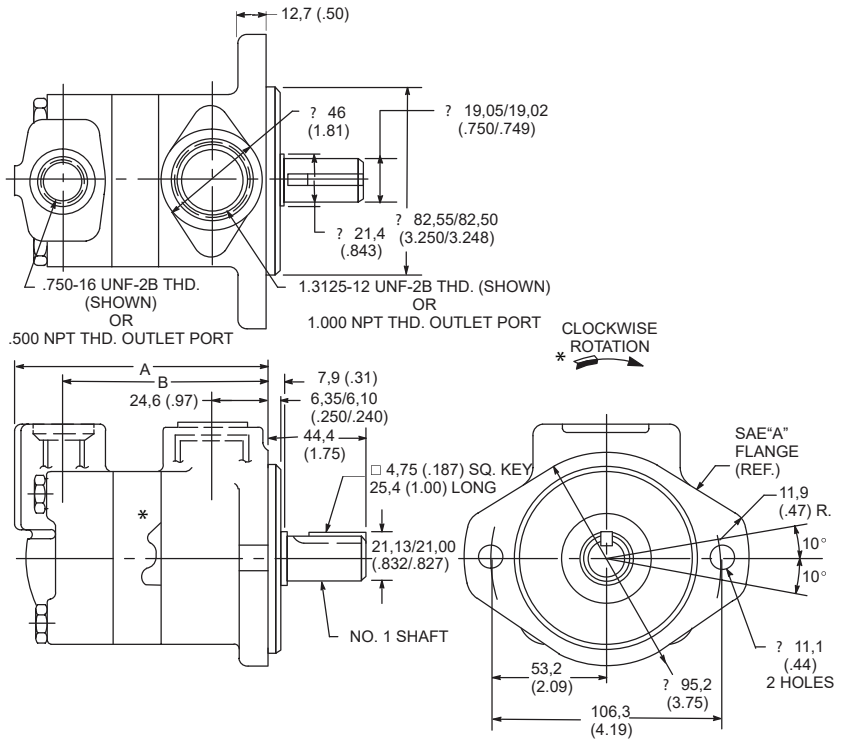
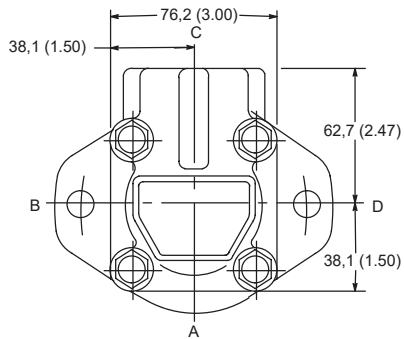

### V10F & V10NF Series

Dimensions in millimeters (inches).  
Additional shaft options shown on page 7.

Delivery @ 1200 rpm & 100 psi	Dimensions	
	A	B
1 USgpm	128,8 (5.07)	109,5 (4.31)
2 USgpm	128,8 (5.07)	109,5 (4.31)
3 USgpm	128,8 (5.07)	109,5 (4.31)
4 USgpm	135,1 (5.32)	115,8 (4.56)
5 USgpm	135,1 (5.32)	115,8 (4.56)
6 USgpm	140,2 (5.52)	120,9 (4.76)
7 USgpm	140,2 (5.52)	120,9 (4.76)

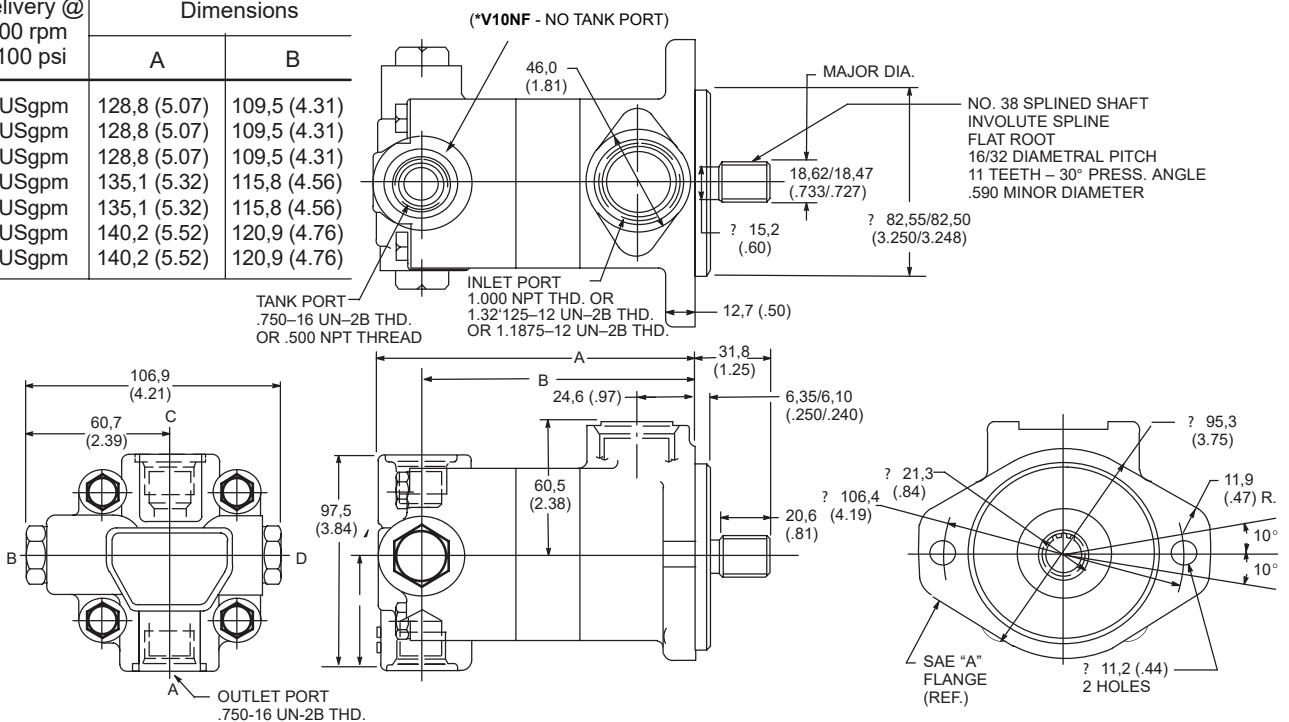

## Installation Dimensions

### V10P Series

Dimensions in millimeters (inches).  
Additional shaft options shown on page 7.

Delivery @ 1200 rpm & 100 psi	Dimensions	
	A	B
1 USgpm	130,0 (5.12)	109,5 (4.31)
2 USgpm	130,0 (5.12)	109,5 (4.31)
3 USgpm	130,0 (5.12)	109,5 (4.31)
4 USgpm	136,4 (5.37)	115,8 (4.56)
5 USgpm	136,4 (5.37)	115,8 (4.56)
6 USgpm	141,5 (5.57)	120,9 (4.76)
7 USgpm	141,5 (5.57)	120,9 (4.76)

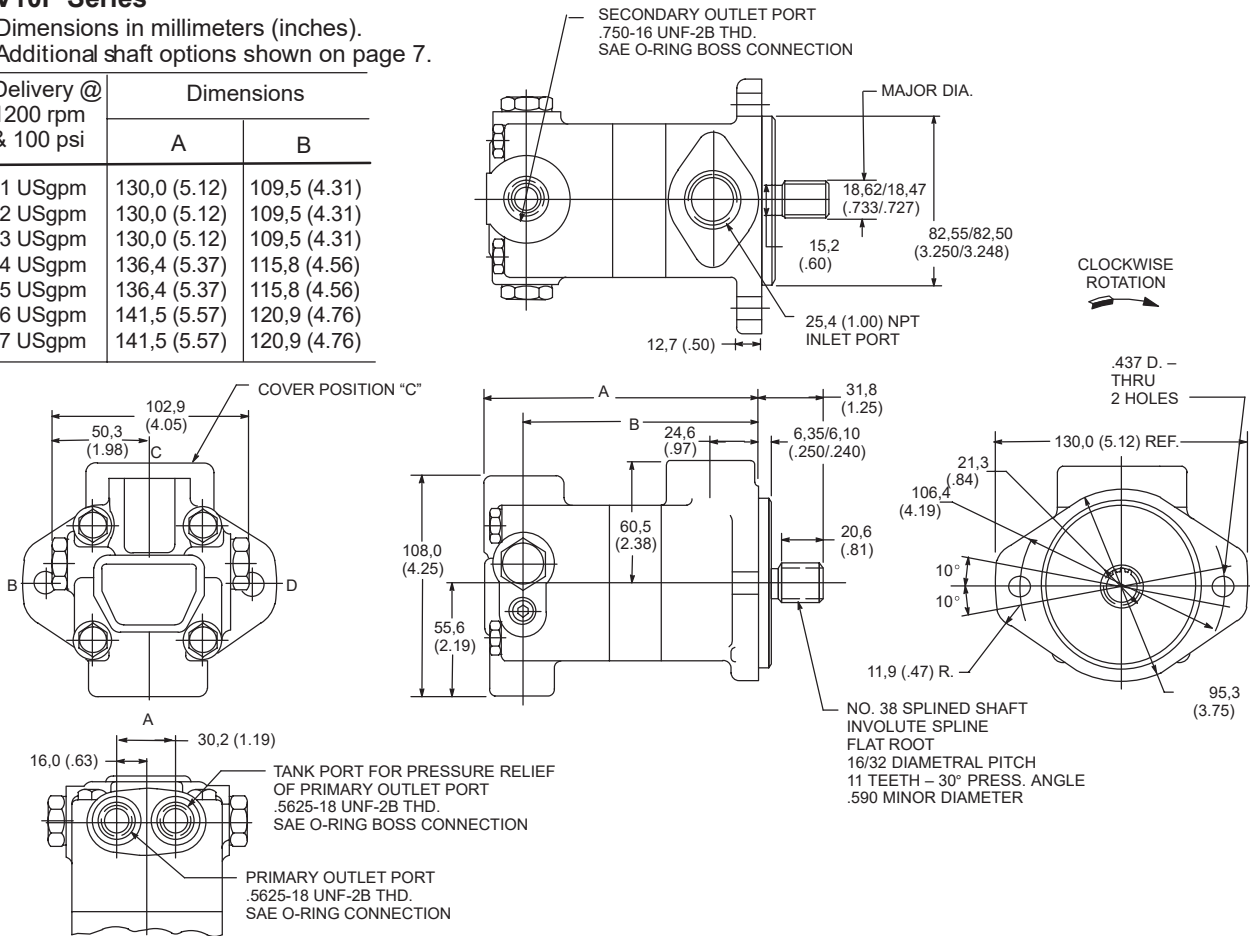

### V20 Series

Dimensions in millimeters (inches).  
Additional shaft options shown on page 7.

Delivery @ 1200 rpm & 100 psi	Dimensions	
	A	B
6 USgpm	125,2 (4.93)	102,1 (4.02)
7 USgpm	131,6 (5.18)	108,4 (4.27)
8 USgpm	131,6 (5.18)	108,4 (4.27)
9 USgpm	131,6 (5.18)	108,4 (4.27)
10 USgpm	136,6 (5.38)	113,5 (4.47)
11 USgpm	136,6 (5.38)	113,5 (4.47)
12 USgpm	140,2 (5.52)	117,1 (4.61)
13 USgpm	140,2 (5.52)	117,1 (4.61)

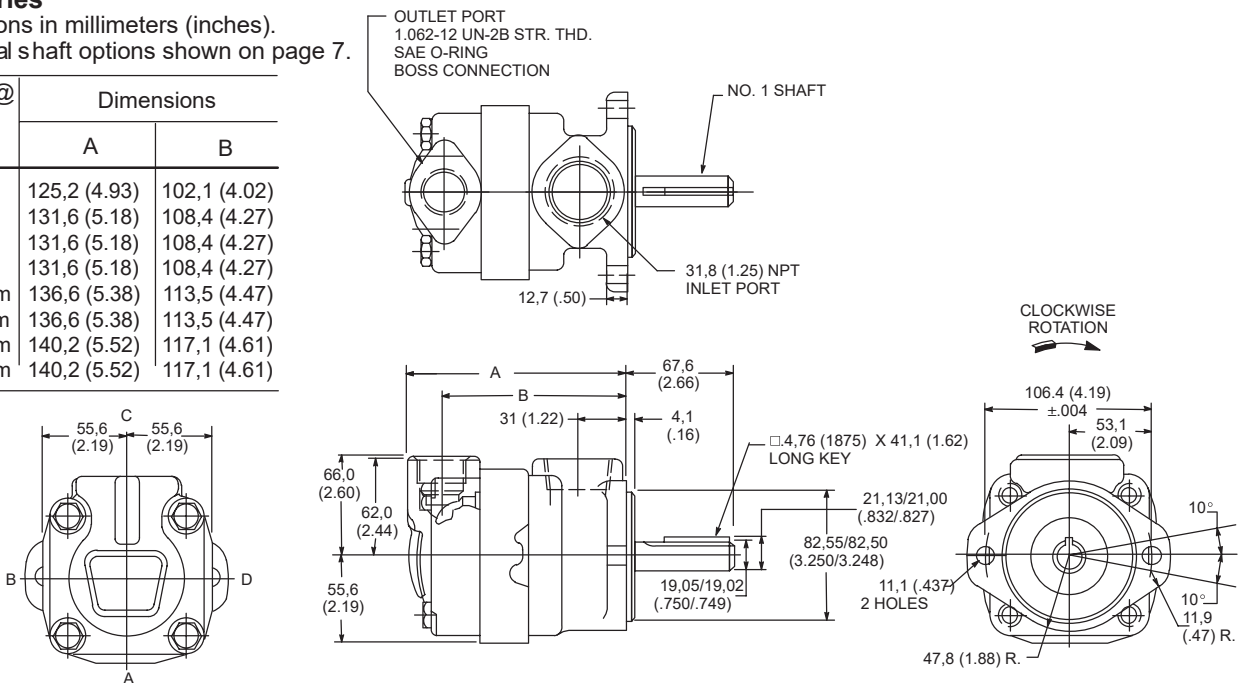

## Installation Dimensions

### V20F, V20NF, & V20P Series

Dimensions in millimeters (inches).

Additional shaft options shown on page 7.

Delivery @ 1200 rpm & 100 psi	Dimensions	
	A	B
6 USgpm	149,6 (5.89)	125,7 (4.95)
7 USgpm	156,0 (6.14)	132,1 (5.20)
8 USgpm	156,0 (6.14)	132,1 (5.20)
9 USgpm	156,0 (6.14)	132,1 (5.20)
10 USgpm	161,0 (6.34)	136,9 (5.39)
11 USgpm	161,0 (6.34)	136,9 (5.39)
12 USgpm	164,3 (6.47)	140,5 (5.53)
13 USgpm	164,3 (6.47)	140,5 (5.53)

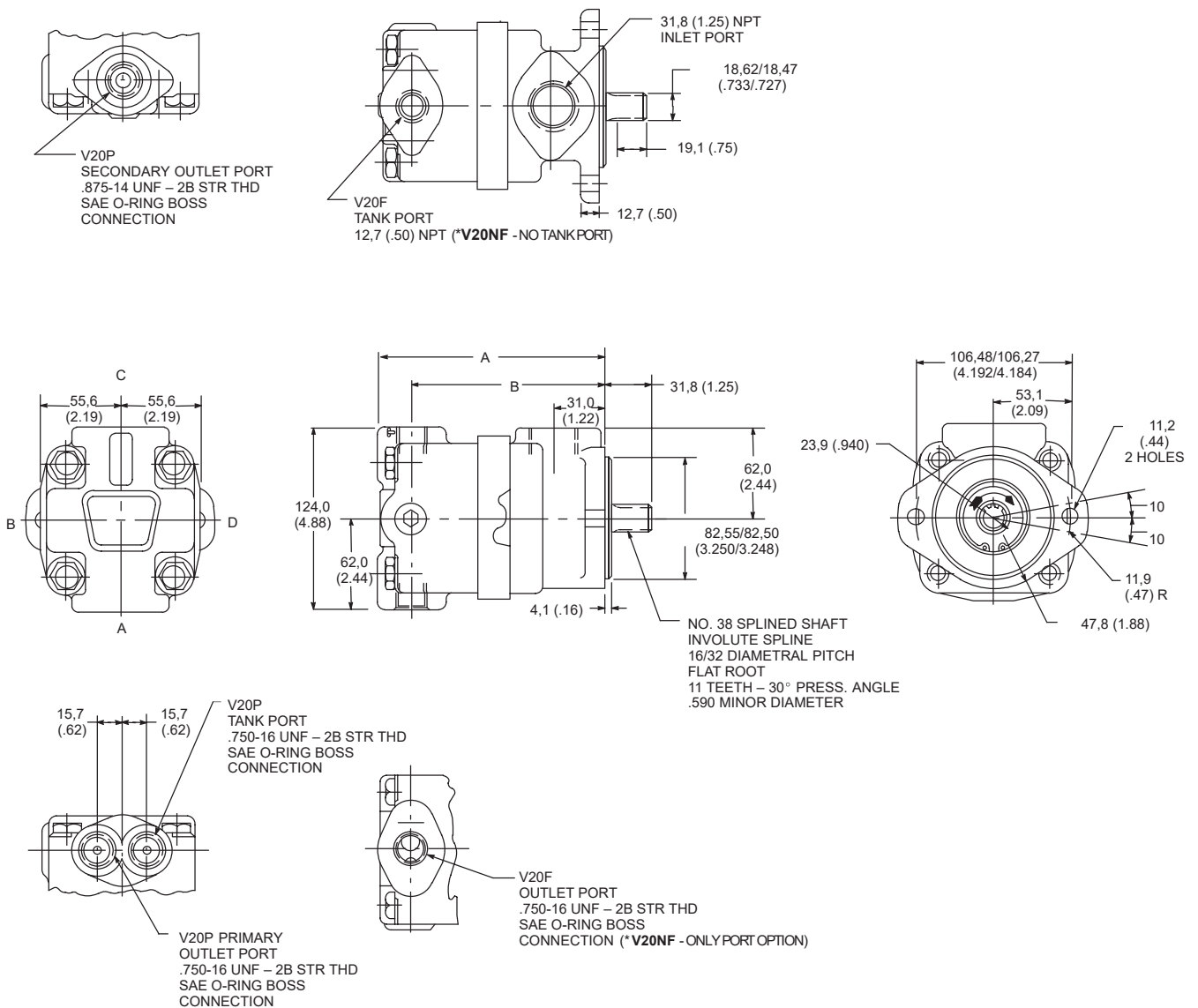

## Optional Shafts

### V10 Series

Dimensions in millimeters (inches)

Note: No. 1 keyed shaft and No. 38 splined shaft shown on page 4.

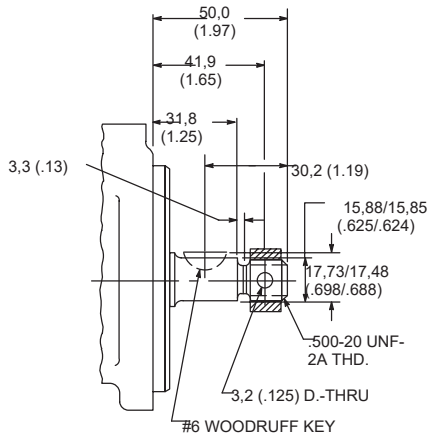

No. 3 shaft extension

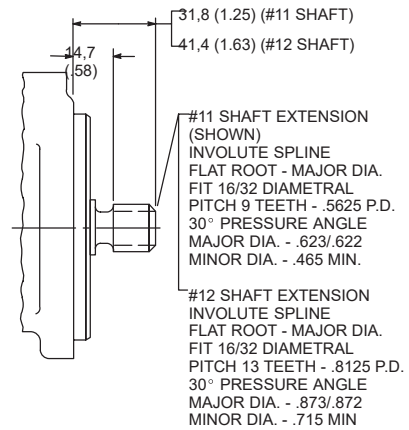

No. 11 & 12 shaft extension

### V20 Series

Dimensions in millimeters (inches)

Note: No. 1 keyed shaft and No. 38 splined shaft shown on pages 5 and 6 respectively. No. 62 splined shaft same as V10 #11 shaft shown above.

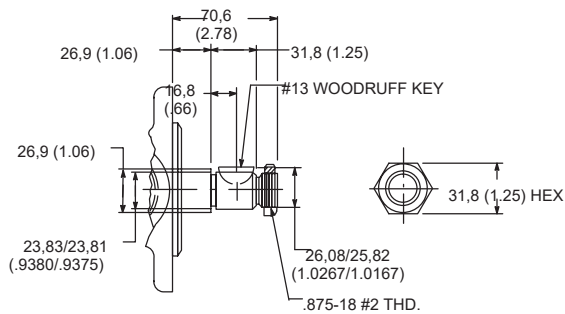

No. 3 shaft extension

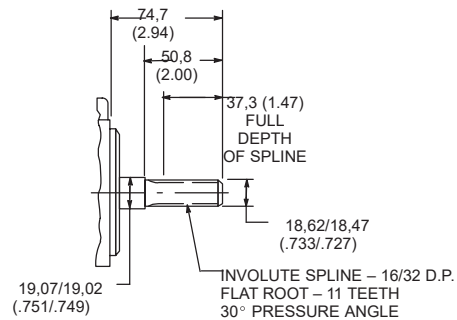

No. 11 shaft extension

#### NOTE:

No. 3 shaft recommended nut torque 170 Nm (125 lb. ft.)

# Typical Performance

## V10 Single Pumps

Performance Constants:  
 Oil temp. 49°C (120°F), viscosity  
 32 cSt (150 SSU) @ 38°C (100°F),  
 inlet pressure zero

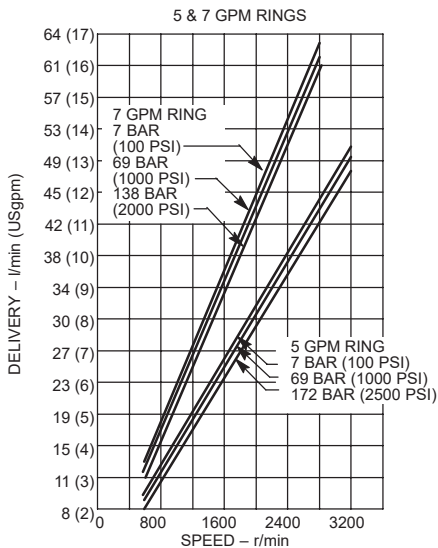
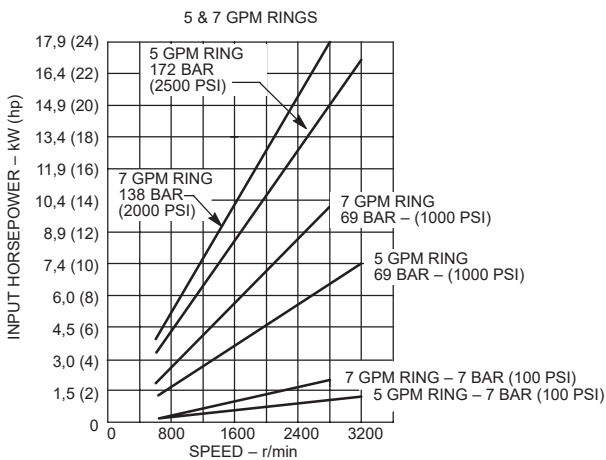
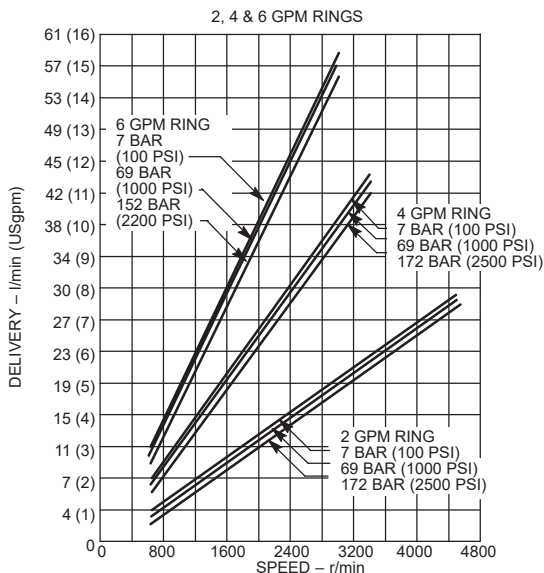
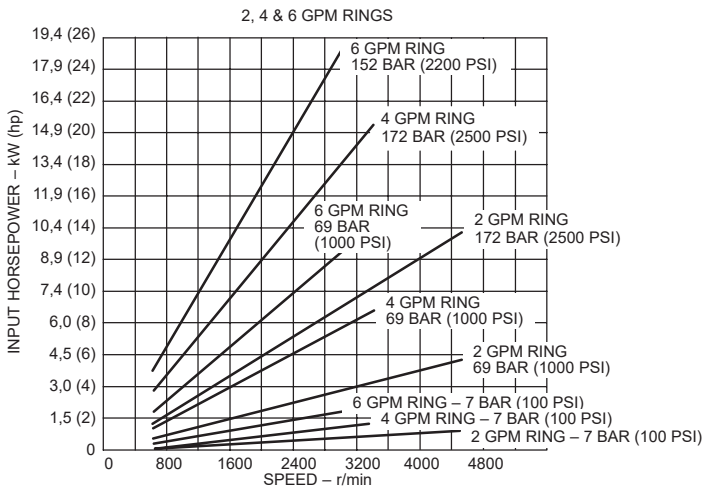
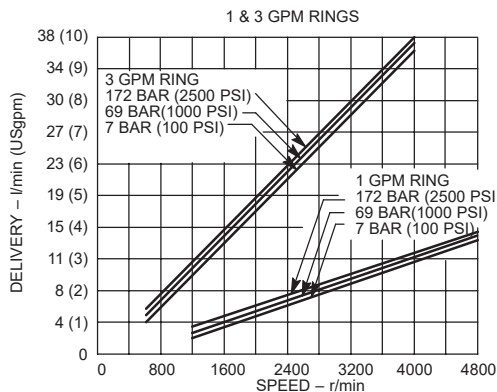
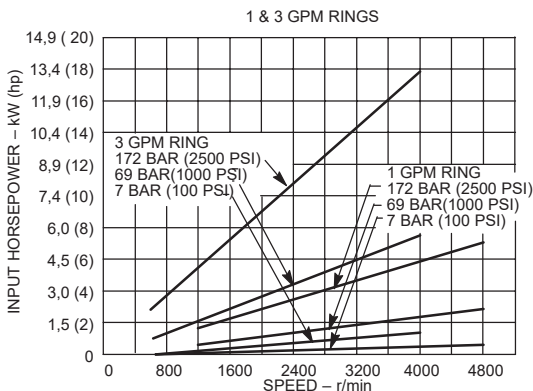



## Typical Performance

### V20 Single Pumps

Performance Constants:

Oil temp. 49°C (120°F), viscosity  
32 cSt (150 SSU) @ 38°C (100°F),  
inlet pressure zero

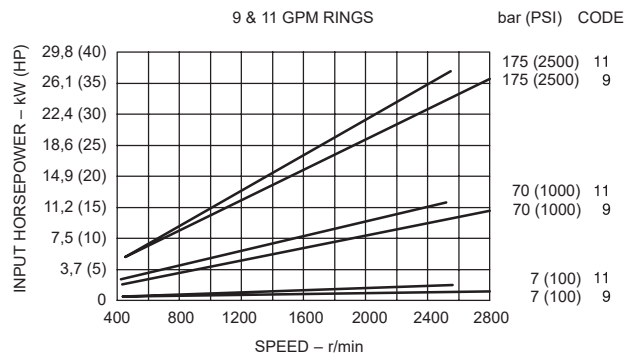
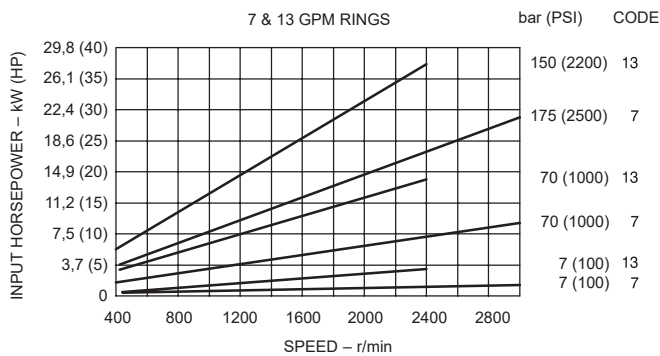
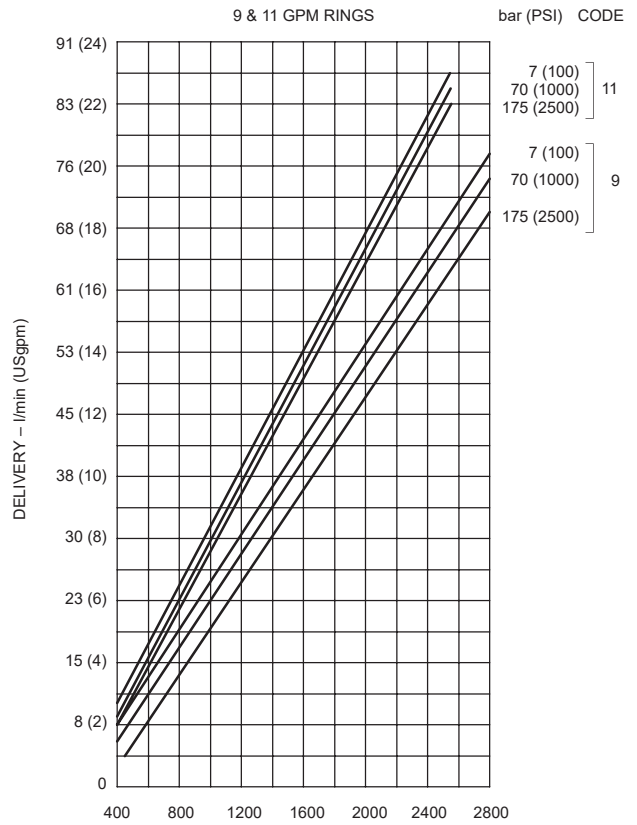
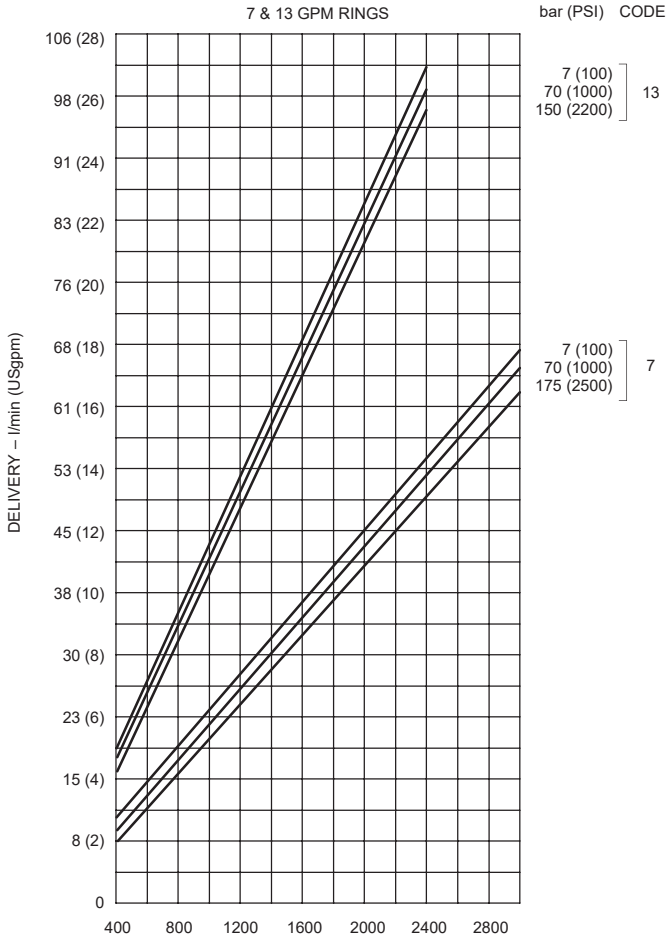

## Typical Performance

### V20 Single Pumps

Performance Constants:  
 Oil temp. 49°C (120°F), viscosity  
 32 cSt (150 SSU) @ 38°C (100°F),  
 inlet pressure zero

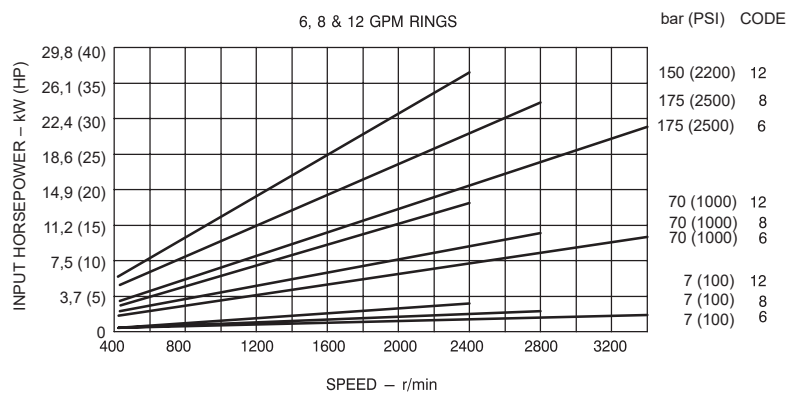
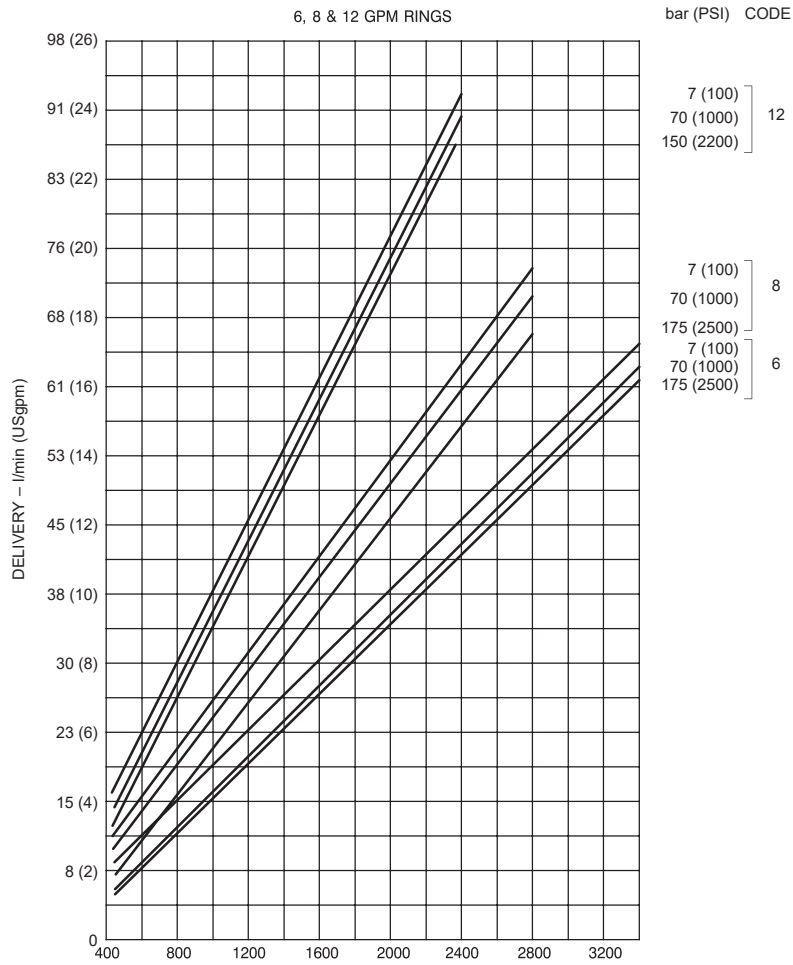

# Priority Valve Models

## V10P Single Pumps

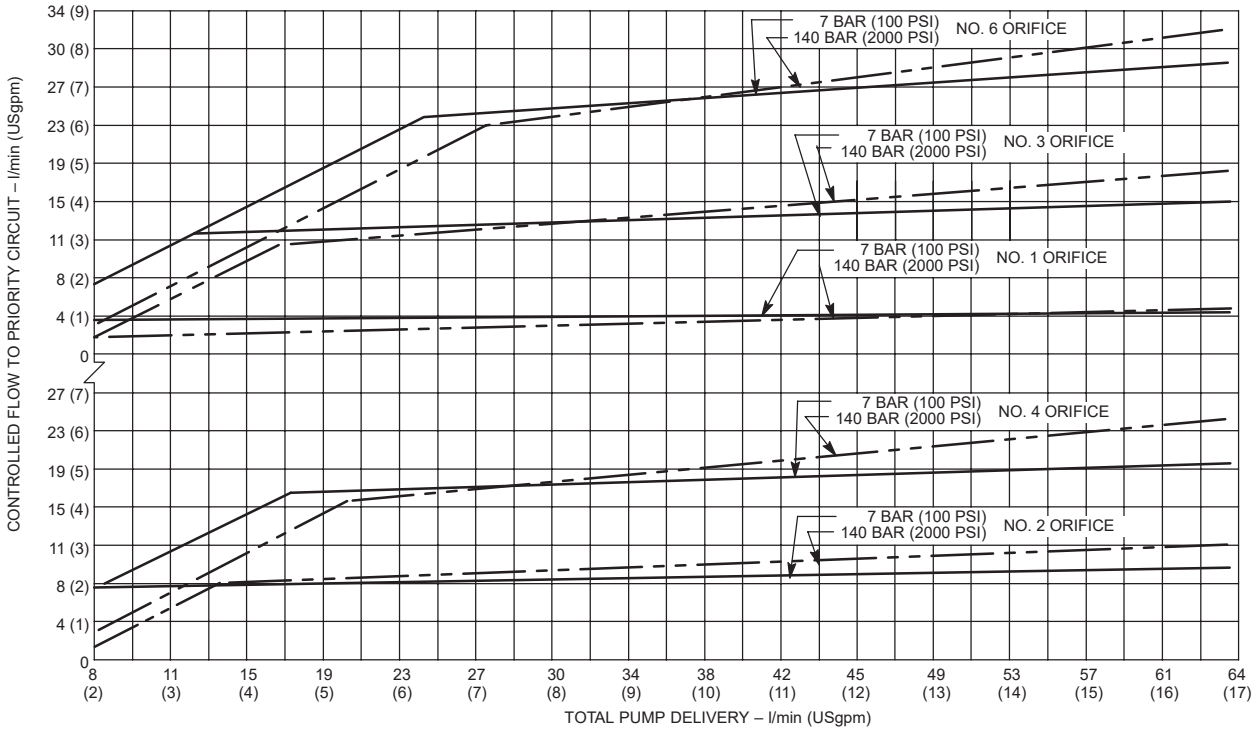

## V20P Single Pumps

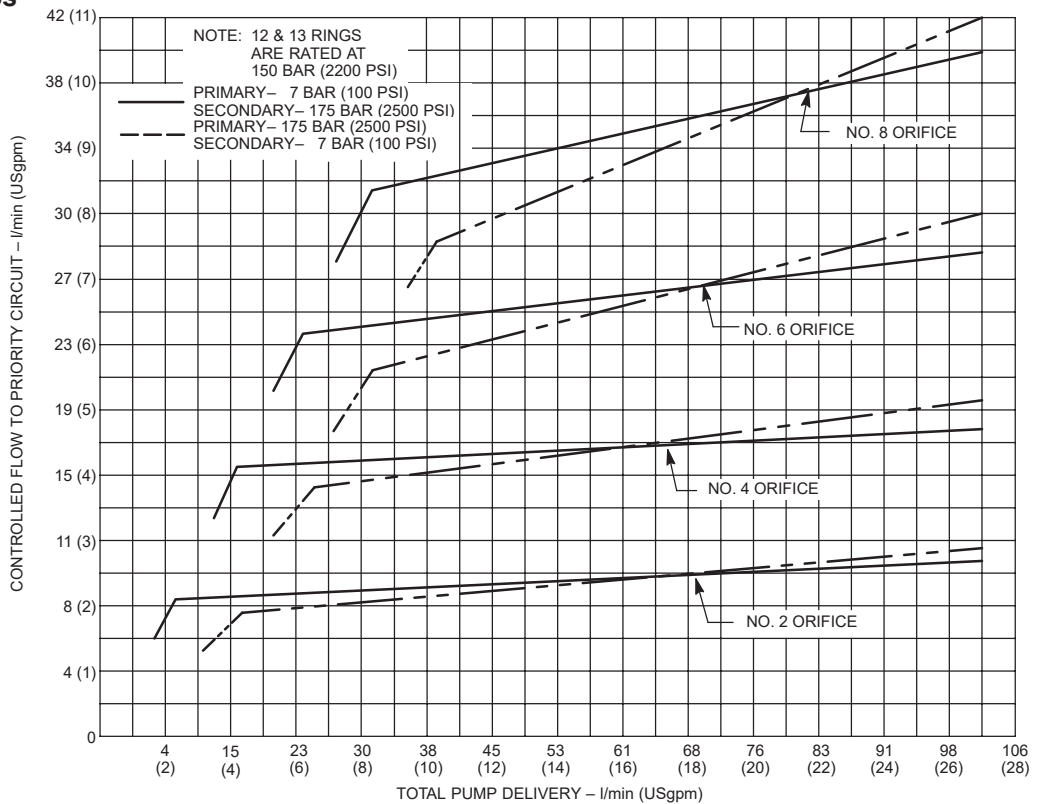

## Typical Performance

### Flow Control Models

#### V10(N)F & V20(N)F Single Pumps

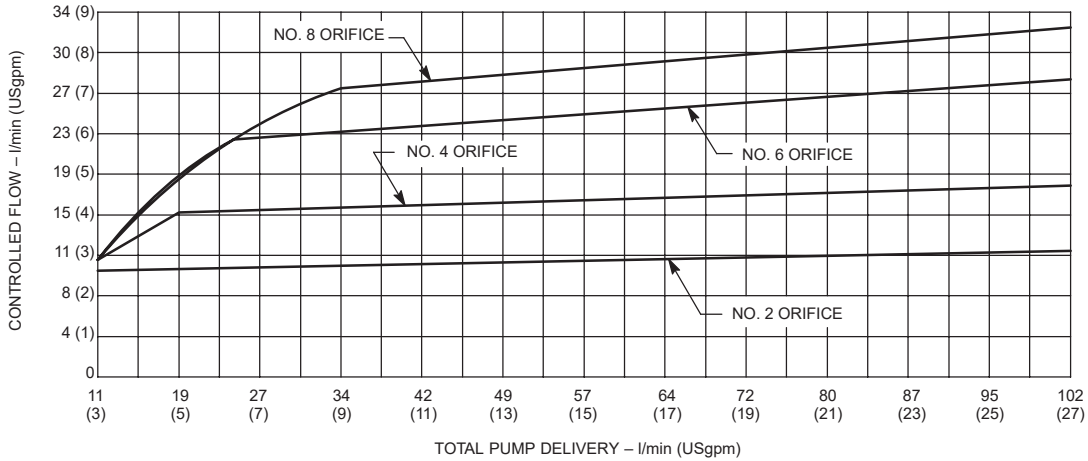

### Speed Correction Curves

#### V10 & V20 Single Pumps

Maximum operating speeds shown on performance curves are for pumps operating at 0 psi inlet condition. To compute maximum operating speeds at other inlet conditions, use appropriate speed rating correction factor.

Example:

Max. speed @ 0 psi inlet      2700 r/min  
 Correction factor @ 5 in. Hg    x .93  
 Max. speed @ 5 in. Hg inlet    2511 r/min

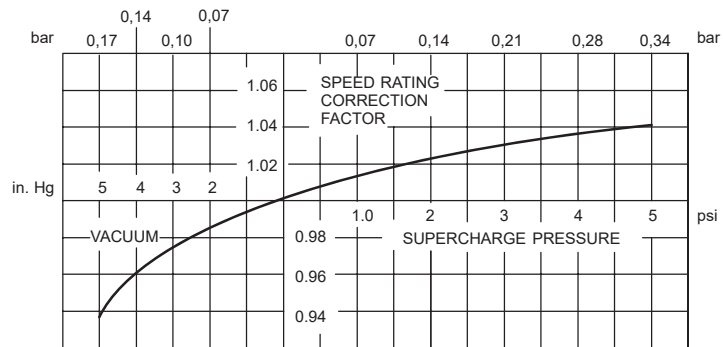

Pump inlet suction should not exceed 5 in. Hg vacuum. Positive pressure on inlet should not exceed 0,7 bar (10 psi).

## Oil Recommendations

The oil in a hydraulic system serves as the power transmission medium. It is also the system's lubricant and coolant. Selection of the proper oil is a requirement for satisfactory system performance and life.

The following recommendations will assist in the selection of suitable oils for use with FluiDyne products. FluiDyne does not publish a recommended oil list by brand name or supplier due to the extremely wide variety of oil types on the market.

In most cases, use of these recommendations will lead to selection of a suitable oil. However, due to the complex nature of oil formulation, the variety of oils available and peculiarities of individual hydraulic applications, there will be rare instances where oil selected on the basis of these recommendations will yield unsatisfactory results. FluiDyne cannot be responsible for such exceptions. In this respect, the customer is encouraged to consult his FluiDyne representative when selecting an oil.

### Important Factors In Selecting An Oil

#### Additives –

Hydraulic fluids contain a number of additive agents which materially improve various characteristics of oil for hydraulic systems. These additives are selected to reduce wear, increase chemical stability, inhibit corrosion and depress the pour point.

Pump performance and reliability are directly affected by the antiwear additive formulation contained in the oil. Oils providing a high level of antiwear protection are recommended for optimum performance and long life.

#### Viscosity –

Viscosity is the measure of fluidity. The oil selected must have proper viscosity to maintain an adequate lubricating film at system operating temperature.

In addition to dynamic lubricating properties, oil must have sufficient body to provide an adequate sealing effect between working parts of pumps, valves, cylinders and motors, but not enough to cause pump cavitation or sluggish valve action.

Optimum operating viscosity of the oil should be between 16 cSt (80 SUS) and 40 cSt (180 SUS).

“Viscosity index” reflects the way viscosity changes with temperature; the smaller the viscosity change, the higher the viscosity index. The viscosity index of hydraulic system oil should not be less than 90. Multiple viscosity oils, such as SAE 10W30, incorporate additives to improve viscosity index (polymer thickened). Oils of this type generally exhibit both a temporary and permanent decrease in viscosity due to oil shear encountered in the operating hydraulic system. The actual viscosity can, therefore, be far less in the operating hydraulic system than what is shown in normal oil data. Accordingly, when such oils are selected, it is necessary to use those with high shear stability to ensure that viscosity remains within recommended limits while in service.

#### Chemical Stability –

Oxidative and thermal stability are essential characteristics of oils for Mobile hydraulic systems. The combination of base stocks and additives should be stable during the expected lifetime of the oil when exposed to the environment of these systems.

#### Suitable Types Of Oil

##### Crankcase Oil –

Crankcase oil having letter designation SC, SD, SE or SF per SAE J183 FEB80. Note that one oil may meet one or more of these designations.

##### Antiwear Hydraulic Oil –

These are produced by all major oil suppliers and should consist of good quality base stocks compounded with antiwear, anti-oxidation, and antirust additives.

Due to the large number of different antiwear hydraulic oils, it is impossible for FluiDyne to test its products with all of them and recommend those that are suitable. Because of this, an evaluation procedure was developed for fluid suppliers to establish the suitability of their products for use in FluiDyne components. Publication M-2952-S, “Pump Test Procedure for Evaluation of Antiwear Hydraulic Fluids for Mobile Systems,” which gives the details of this test procedure, is available on request.

#### Certain Other Types Of Petroleum Oil –

Other oils are suitable if they meet the following provisions:

1. Contain the type and content of antiwear additives found in the above designated crankcase oils, and have passed the pump tests as given in M-2952-S.
2. Have sufficient chemical stability for Mobile Hydraulic system service.
3. Meet the viscosity recommendations shown in the following tables.

#### Oil Viscosity Recommendations

##### Crankcase Oils –

Hydraulic System Operating Temp. Range*	SAE Viscosity Designation
–23°C to 54°C (–10°F to 130°F)	5W, 5W-20, 5W-30
–18°C to 83°C (0°F to 180°F)	10W
–18°C to 99°C (0°F to 210°F)	10W-30, 10W-40
–10°C to 99°C (14°F to 210°F)	20-20W

##### Antiwear Hydraulic Oils

Hydraulic System Operating Temp. Range*	ISO Viscosity Grade
–21°C to 60°C (–5°F to 140°F)	22
–15°C to 77°C (5°F to 170°F)	32
–9°C to 88°C (15°F to 190°F)	46
–1°C to 99°C (30°F to 210°F)	68

\* Temperatures shown are cold (ambient) start-up to maximum operating. During cold start-up, avoid high-speed operation of hydraulic components until the system is warmed up to provide adequate lubrication.